

> Instructions

Thule Ladder Tilt 311

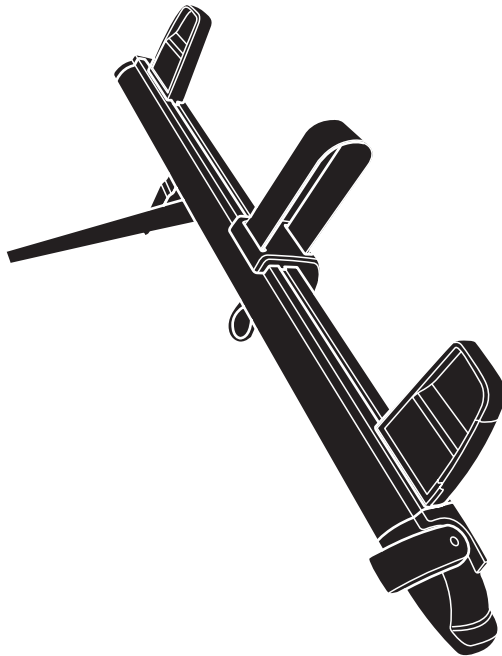

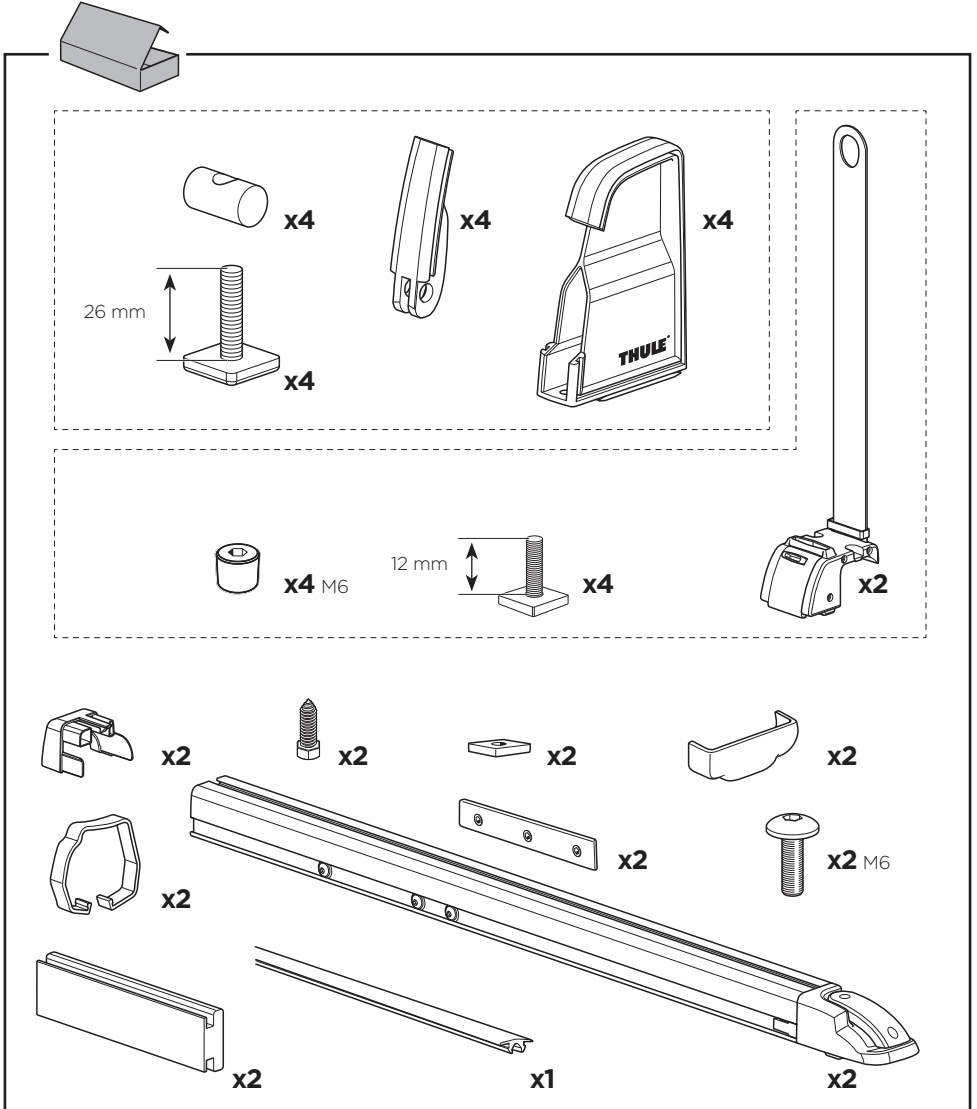
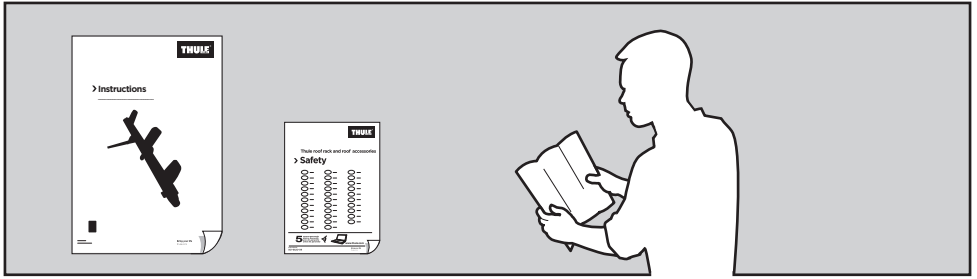
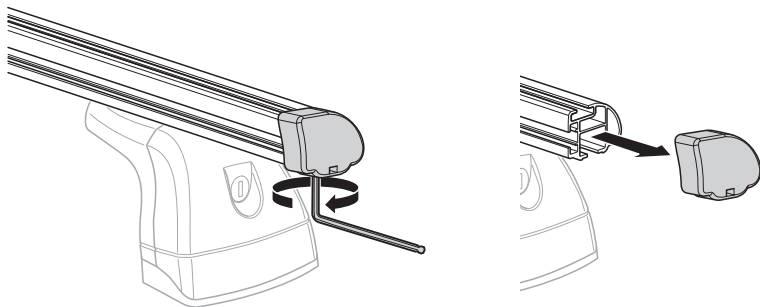
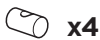
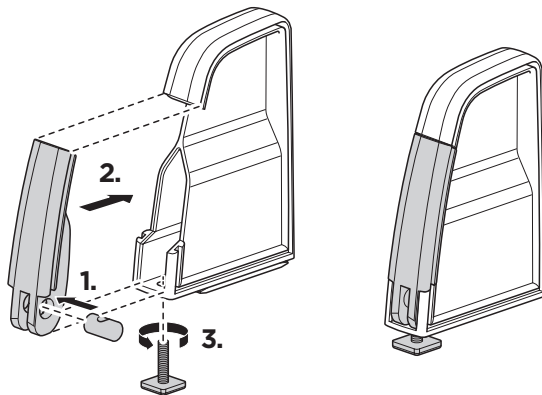
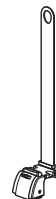
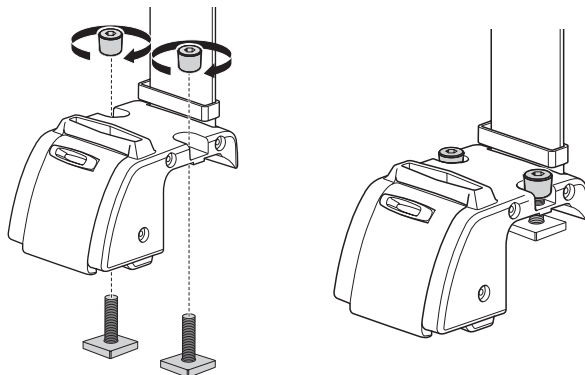

1**2****x4****x4****x4****x4****x4****x4****x2**

3



x4

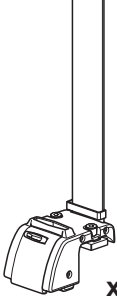

x2

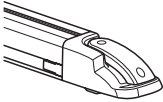

x2

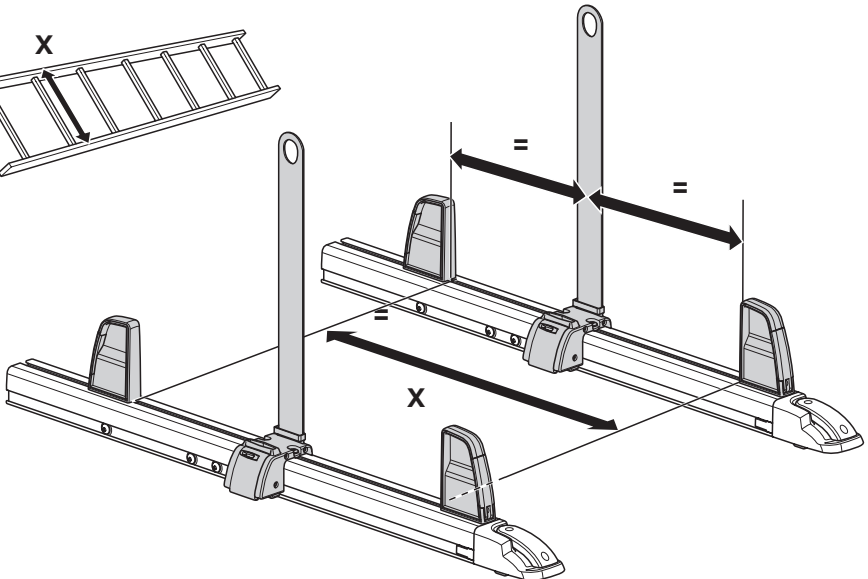
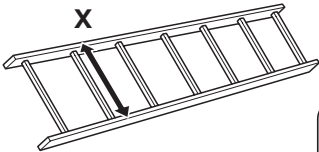
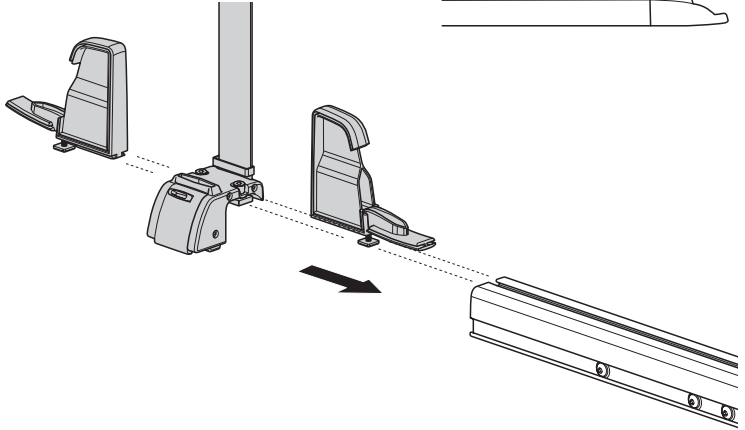
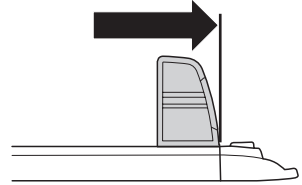
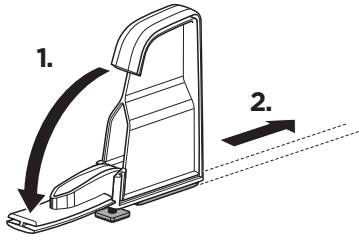

4

4 Nm

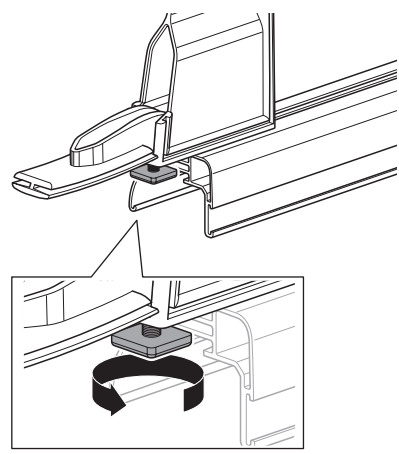
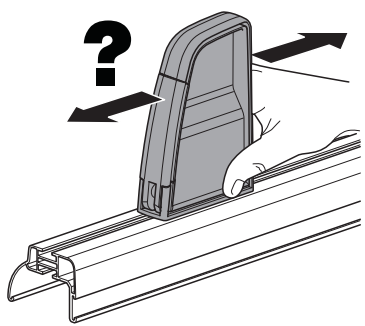
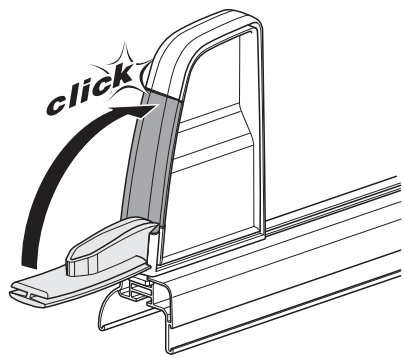
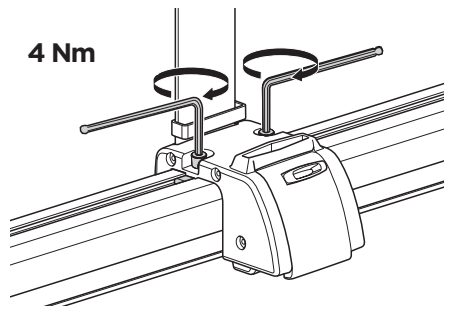

10-15 kg

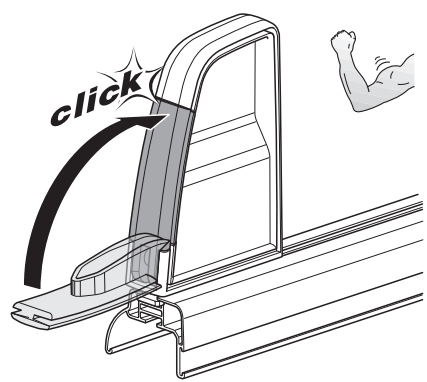

5

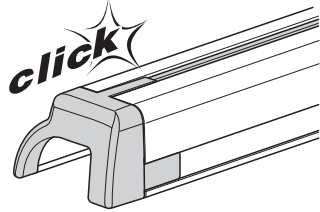
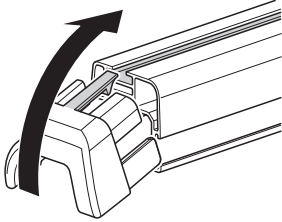
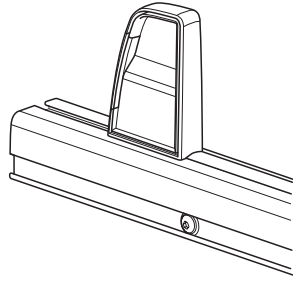
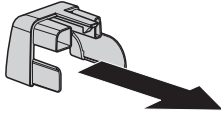
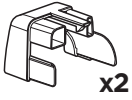

6

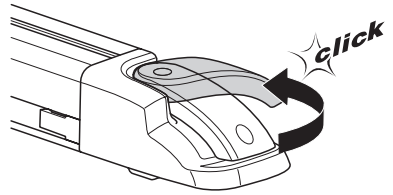
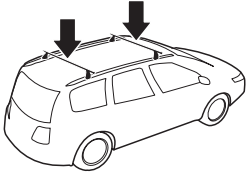

ok

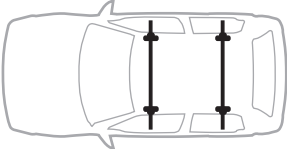

Not ok

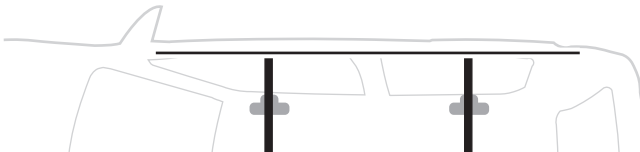
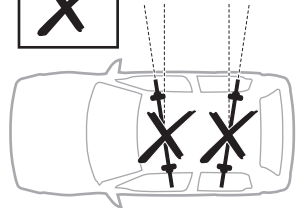

7

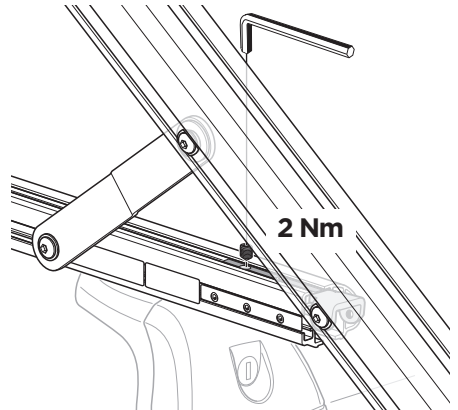
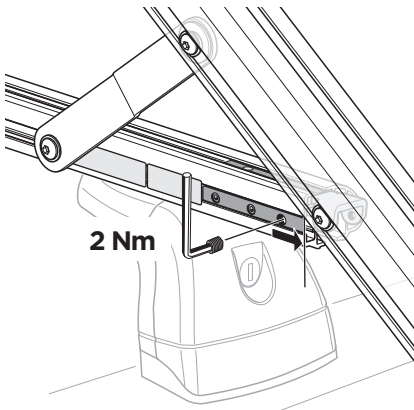
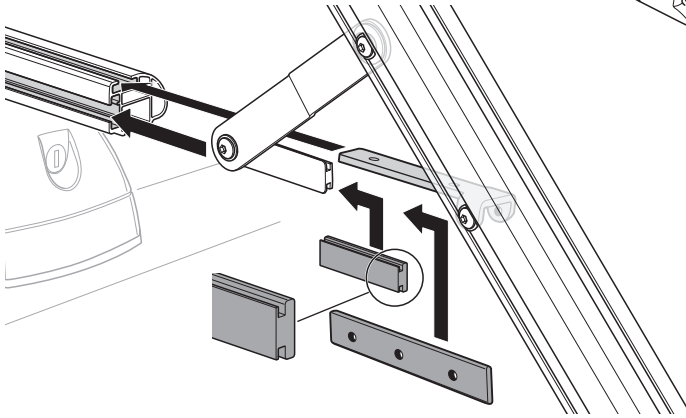
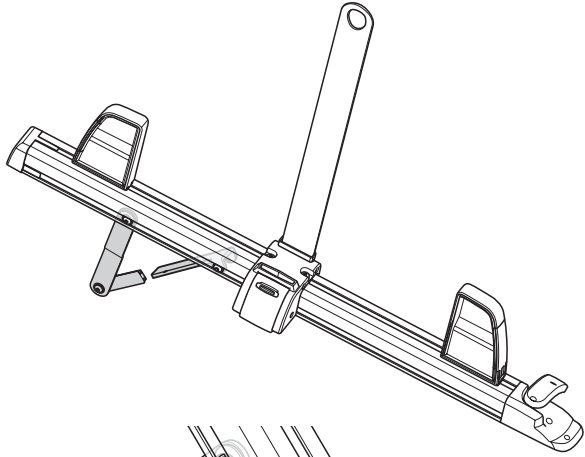
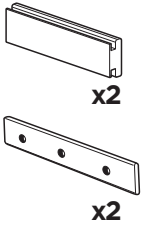

8



x2



x2



x2

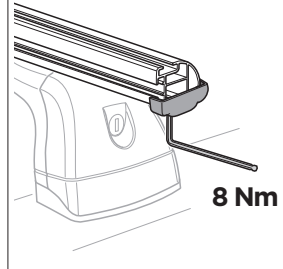
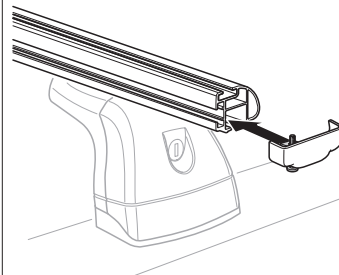
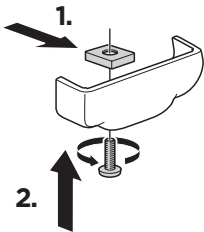
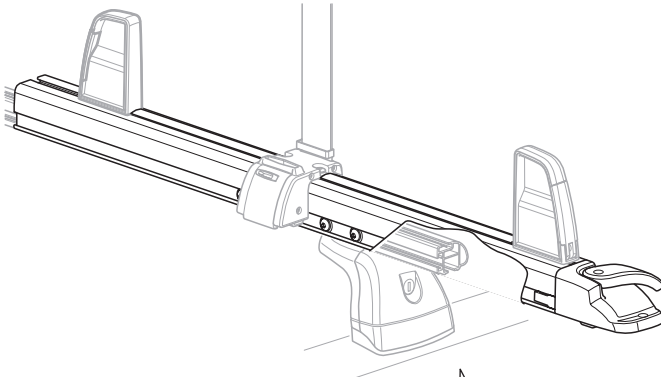
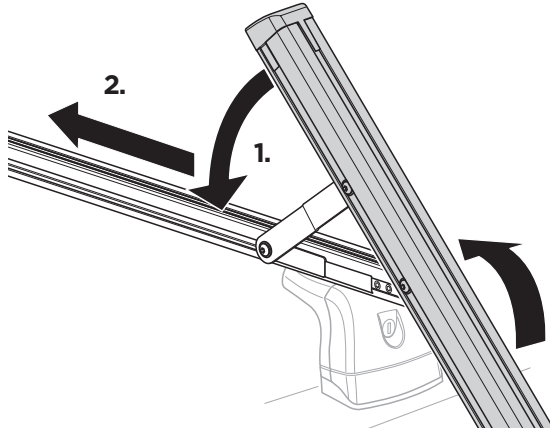

9



1.

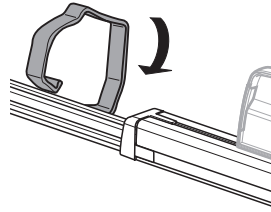
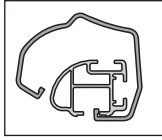

2.

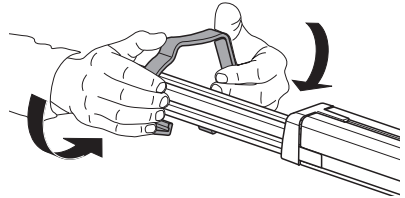
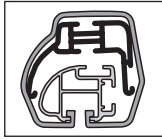

3.

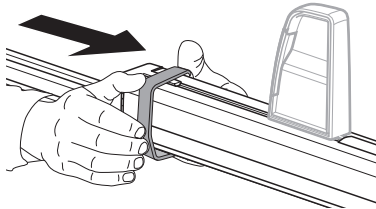

4.

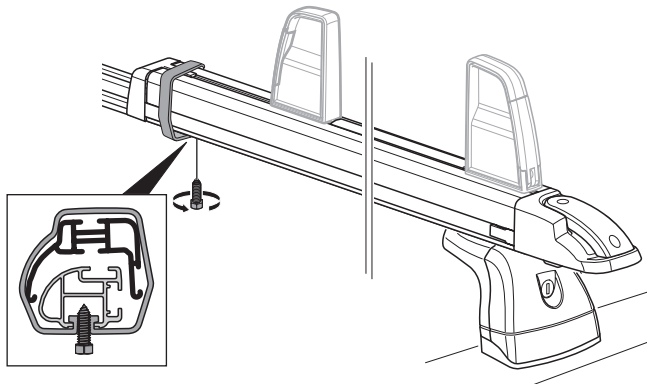

10

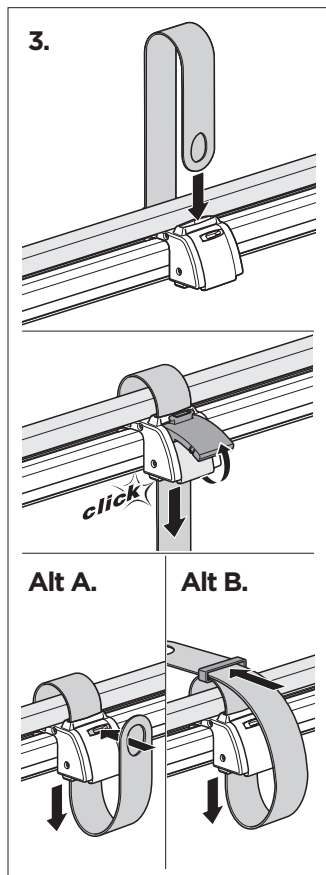
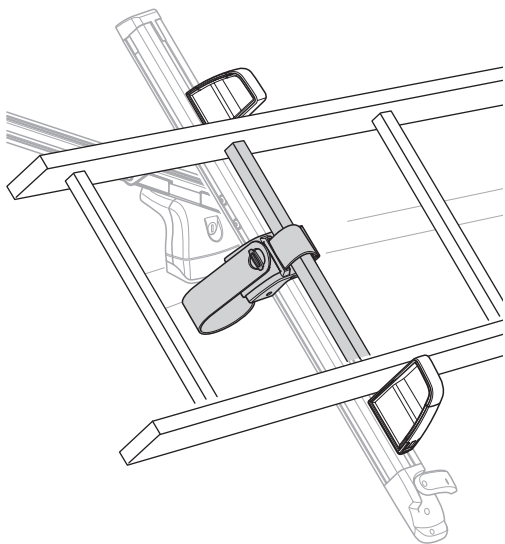
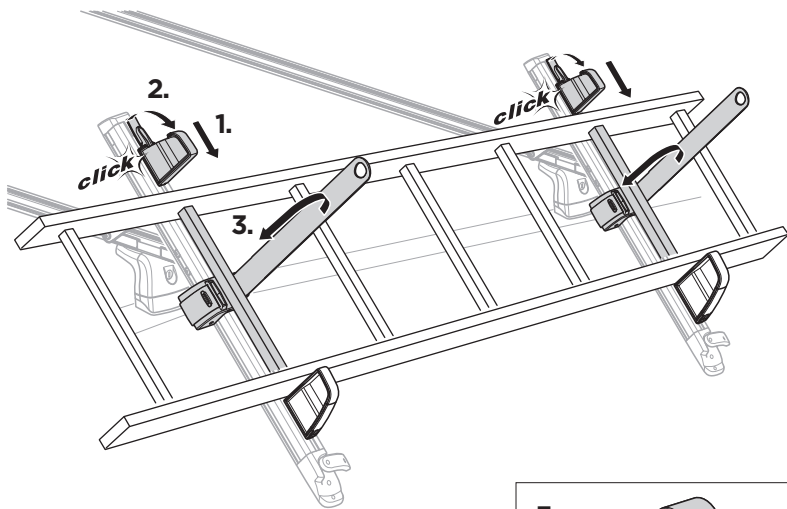

i

ok

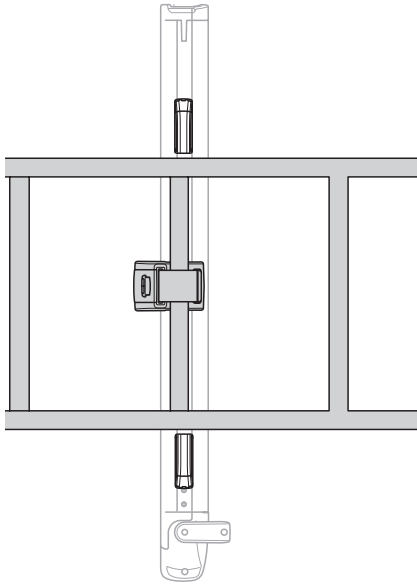
Not ok

310

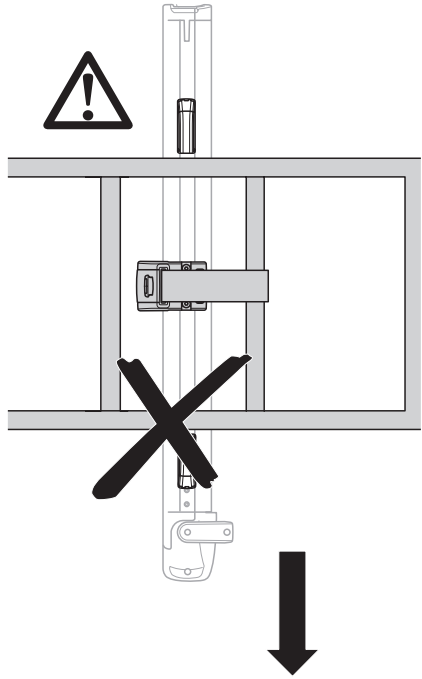

11

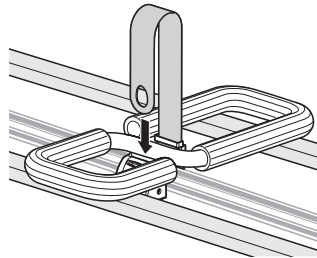

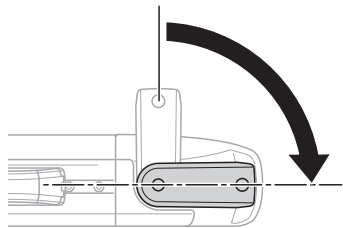
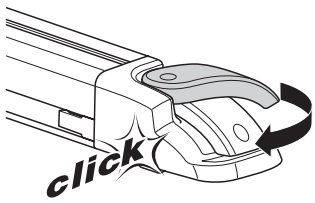
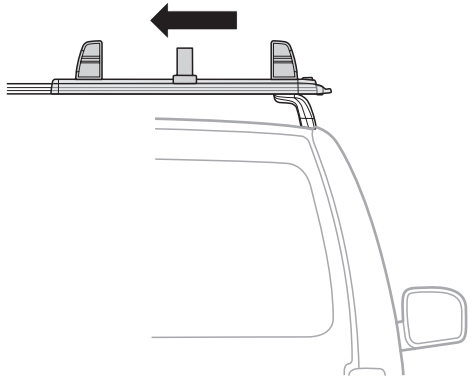
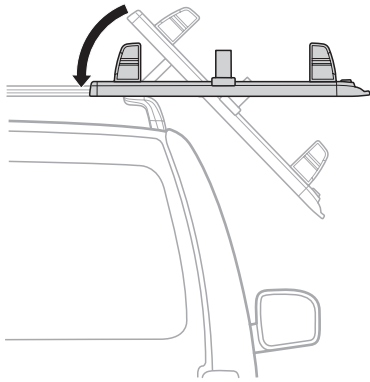
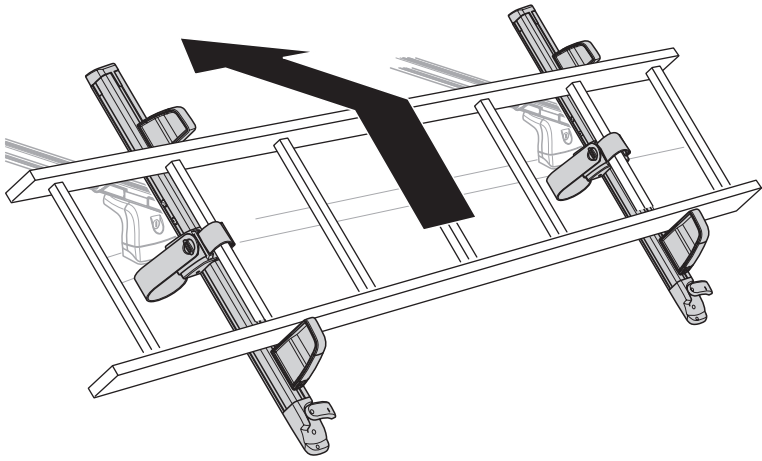
i

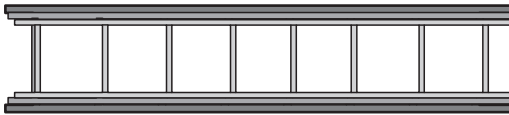
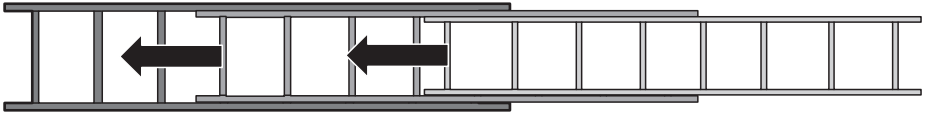

Max 3

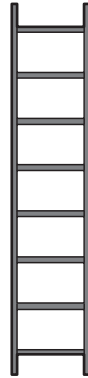

i

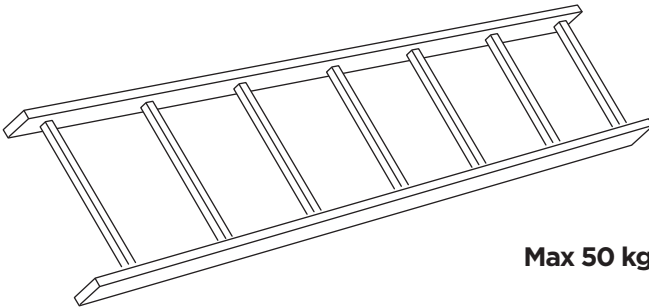

Max 50 kg

i

310

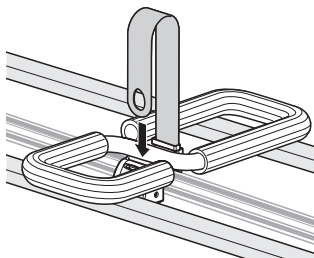

i

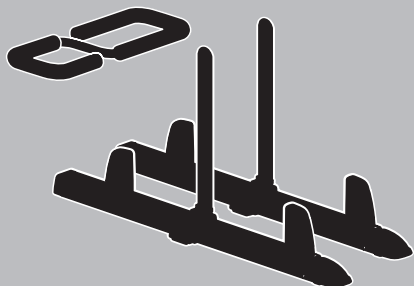
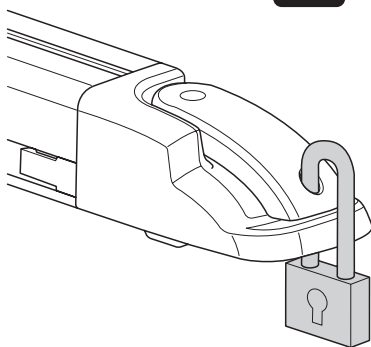
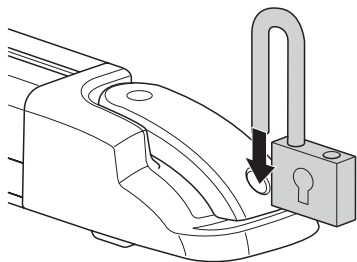

10,5 kg

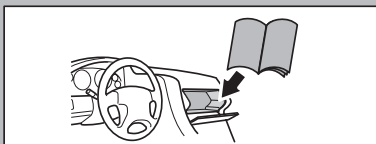



1.

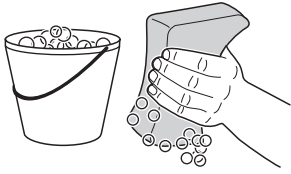

2.

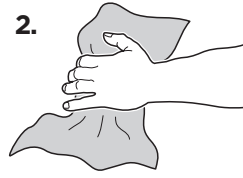

3.

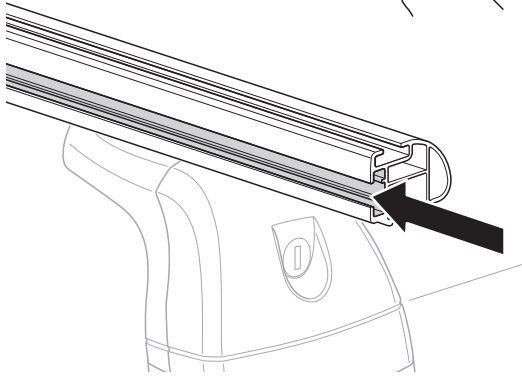



Thule Sweden AB, Borggatan 5
335 73 Hillerstorp, SWEDEN

› PART OF THULE GROUP



info@thule.com

© Thule Group 2018. All rights reserved.



www.thule.com

501-7171-09